



# Operating Instructions

## Control Units for Belt Drives

### EBF-05

BA

Rhein-Nadel Automation GmbH

## Contents

<b>1</b>	<b>Technical Data</b>	
1.1	Functional description .....	3
1.2	EC Conformity .....	3
1.3	Technical data .....	3
<b>2</b>	<b>Safety instructions .....</b>	<b>4</b>
<b>3</b>	<b>Instructions for the initial start-up .....</b>	<b>4</b>
3.1	Factory setting .....	4
3.2	Standard programming .....	5
3.3	Functions of the display and buttons .....	5
3.4	External release .....	6
3.5	Alarm .....	6
<b>4</b>	<b>Mechanical construction .....</b>	<b>6</b>
<b>5</b>	<b>Dimensioned drawing .....</b>	<b>7</b>
<b>6</b>	<b>Connection diagram .....</b>	<b>7</b>



Declaration of conformity  
as defined by  
Low voltage directive 2014/35/EU  
and EMC directive 2014/30/EU

Herewith we declare that the product complies with the following provisions:

Low voltage directive 2014/35/EU  
EMC directive 2014/30/EU

applied harmonized standards:

DIN EN 60204 T1  
EN 61439-1

remarks:

Rhein-Nadel-Automation

-----  
Managing Director  
Jack Grevenstein



## 1.1 Functional description

Control units of the EBF 05 series are microprocessor-controlled units to adjust the speed settings on RNA belt drives, elevators and plate conveyors. There are two types available for power adaptation: 0.370 kW and 0.75 kW.

From the monophase mains – 230 V, 50 or 60 Hz – the units generate a three-phase mains with an adjustable frequency.

Asynchronous squirrel-cage motors driven with this are continuously adjustable and the range reaches from 17 Hz to 85 Hz. The lower limits result from the minimum speed needed for self-ventilation, the upper limits set the maximum permissible speed according to the manufacturer's instructions.

A release input for a powerless start and stop of the drive as well as a signal output to recognise a fault have been led to the terminal strip and are available to the user by means of additional wiring.

## 1.2 EC Conformity

The control device corresponds to the following regulations:

**Low voltage directive 2014/35/EU**

**EMC directive 2014/30/EU**

Applied harmonized standards:

**DIN EN 60204 T1**

**EN 61439-1**

## 1.3 Technical Data

Mains voltage	230 V +10% 50/60Hz
Output voltage	3 x 0-210 Volt AC
Output frequency	0.5 – 120 Hz
<u>Power class 370</u>	
Motor rating	370 W
Rated current of the unit	2.1 A
<u>Power class 750</u>	
Motor rating	750 W
Rated current of the unit	3.6 A
Set-point value	Potentiometer 10k $\Omega$
Release	Contact
Status relay	250 V, 2A
Permissible ambient temp.	0 – 50 °C
Measurements 370 and 750	150 x 205 x 180 mm
Radioshielding and resistance to jamming	according to EMC Guideline conformity
Type of protection	IP54
Type of protection	IP54

## 2 Safety instructions

The safety instructions should by all means be read and understood. The observance of these instructions ensures that valuable material is maintained and damage to health is avoided.

One must make sure that every person working with this control unit is acquainted with the safety instructions and also follows them.

The unit described here is a control unit for the operation of RNA belt drives. The limiting values in the technical data are to be observed.

**Note!**

This hand indicates tips on how to use the control unit.

**Attention!**

This warning triangle indicates safety instructions. Non-observance of this warning can result in serious injuries or death!

Work on electrical equipment of the machine may only be carried out by a qualified electrician or by an instructed person under the directions and supervision of a qualified electrician according to the electrotechnical regulations!



Please observe all notes on safety and danger on the machine!

The electrical equipment of a machine is to be inspected and checked regularly. Defects like loose connections or damaged cables have to be eliminated immediately!



Before opening the unit, pull the mains plug **and wait at least 5 minutes!**

The dangerous energy in the intermediate circuit degrades only slowly after disconnection from the mains!

**Non-observance means danger to life and limb!**



Before putting the machine into operation, please make sure that the protective conductor (PE) is installed at the connecting point and that it is intact. To check the protective conductor, only approved testing equipment may be used.

### 3 Instructions for the initial start-up



The connecting cable between the control unit and the conveyor belt has to be screened, and the screen connected on both sides to the protective conductor.

**The maximum cable length is 2 metres.**



Before connecting to the mains and switching on the control unit, the following points must be checked:

- Is the INTENDED USE sure?
- Does the indicated supply voltage on the control unit correspond with the local network?

After having connected the control unit to the power supply and switched on the mains switch, the conveyor belt begins to move. A restart muting after a power failure is not provided for with these control units.

#### 3.1 Factory setting

The control unit is programmed to the set-point value by a potentiometer.

If a control unit is delivered together with a conveyor belt, the operational parameters will already have been programmed for this conveyor belt. The settings are recorded on the parameter sheet.

If the data of the driving motor is unknown, the following settings will be made:

- Minimum frequency 17 Hz;
- Maximum frequency 85 Hz;
- Current limit 0 A;

Start/Stop ramp 1 sec. each

### 3.2 Standard programming of the frequency converter EBF 05

Display	Meaning	Setting value
bfr	Motor frequency according to rating plate	50 Hz
ACC	Run-up time	1 sec
dec	Run-down time	1 sec
LSP	Small frequency	17 Hz
HSP	Large frequency	85 Hz
ItH	Thermal motor current	0A
tCC	Type of control	ACT - 2C (2-wire control)
tct	Logic 0 or 1 is taken into account for switching on or off	LEL
Atr	Automatic restart	nO

### 3.3 Functions of the display and buttons

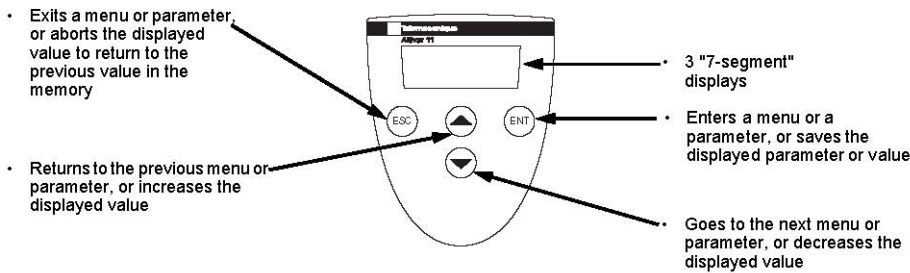

Pressing or does not store the selection.

Save the selection :

Example:

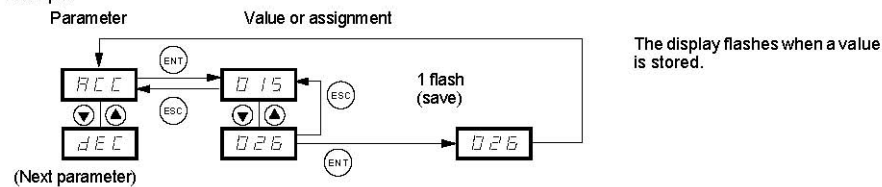

**Normal display, with no fault present and no startup:**

- rdY: Drive ready
- 43.0: Display of the parameter selected in the SUP menu (default selection: frequency reference).
- dcb: DC injection braking in progress
- nSt: Freewheel stop

**If there is a fault, it is shown with a flashing display.**

### 3.4 External release

- Contact release  
Remove bridge of binder 10 – 11,  
loop in a voltage-free contact.  
The connecting cable to the contact has to be screened.  
The screen has to be connected in the control unit to the protective conductor.  
The maximum cable length is 5 m; laying them together with cables that have perturbing radiation must be avoided.

### 3.5 Alarm

The alarm relay is closed when the frequency converter is under voltage and does not show any faults. When there is a fault (or a converter without voltage), the contact drops.

Unlocking the converter after a fault is done as follows:

- by switching it off and waiting until the alarm on the display extinguishes, then by switching the converter on again;
- automatically in the cases described under “Automatic Restart“ (menu FUn, Atr = YES);
- by a logic input that is assigned to the function “Reset“ (menu Fun, rSF = LI●).

## 4 Mechanical construction

The construction of the control unit is divided into two parts: underpart of the housing with fixing plate and upper part of the housing with front panel.

The underpart laterally bears the mains switch and the cable bushing. The mains filter and the terminal/contact strip XS1 have been placed inside.

The frequency converter has been placed in the upper part together with the thermal coupler; the front panel with the potentiometer closes the upper part.

For the purpose of changing the frequency converter or installing additional wiring, 4 slotted screws in the circular taperings of the upper part are to be loosened after having removed the front panel and then to detach the upper from the underpart. The terminal/contact strip is now accessible and can also be detached. The underpart remains on the body of the machine; the installation is now easily accessible.

When mounting, one must make absolutely sure that the seals are properly in place, otherwise the type of protection is no longer given.

## 5. Dimensioned drawing

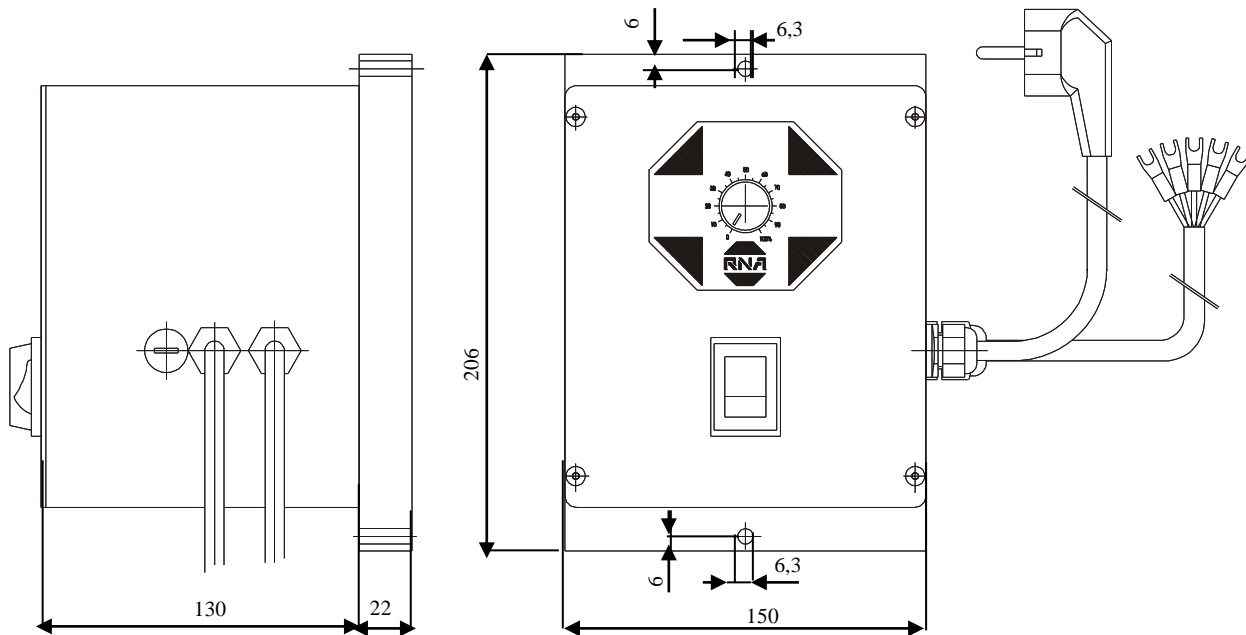

## 6. Connection diagram

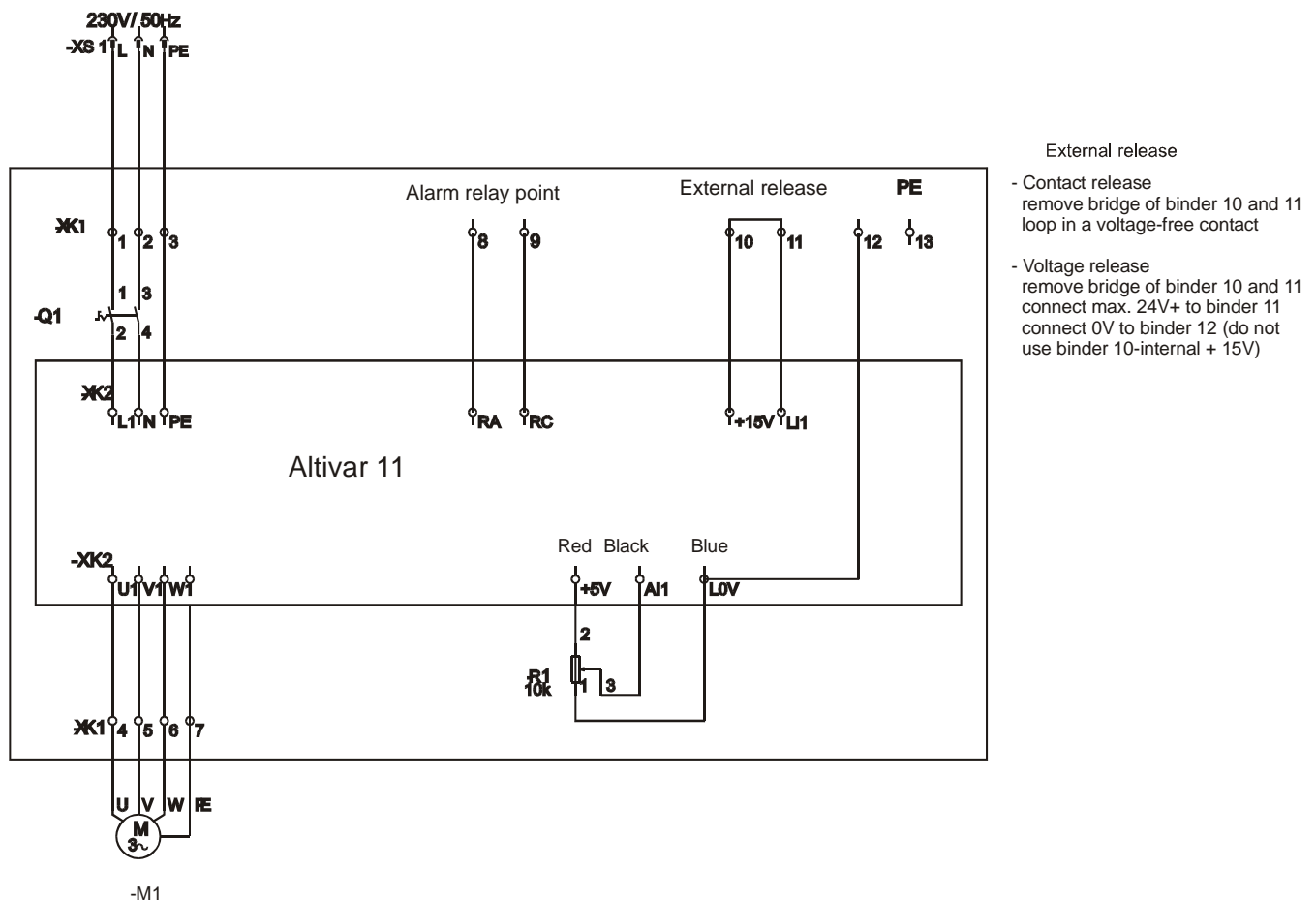

The control binders that are not connected provide for a number of additional functions and monitorings, which are to be selected through parameterization. A detailed description can be found in the operating instructions of the frequency converter.



D

### **Rhein-Nadel Automation GmbH**

Reichsweg 19/23 • D - 52068 Aachen  
Tel (+49) 0241/5109-159 • Fax (+49) 0241/5109-219  
Internet [www.rna.de](http://www.rna.de) • Email [vertrieb@rna.de](mailto:vertrieb@rna.de)

### **Rhein-Nadel Automation GmbH**

Zweigbetrieb Lüdenscheid  
Nottebohmstraße 57 • D - 58511 Lüdenscheid  
Tel (+49) 02351/41744 • Fax (+49) 02351/45582  
Email [werk.luedenscheid@rna.de](mailto:werk.luedenscheid@rna.de)

### **Rhein-Nadel Automation GmbH**

Zweigbetrieb Ergolding  
Ahornstraße 122 • D - 84030 Ergolding  
Tel (+49) 0871/72812 • Fax (+49) 0871/77131  
Email [werk.ergolding@rna.de](mailto:werk.ergolding@rna.de)

### **PSA Zuführtechnik GmbH**

Dr. Jakob-Berlinger-Weg 1 • D – 74523 Schwäbisch Hall  
Tel +49 (0)791/9460098-0 • Fax +49 (0)791/9460098-29  
Email [info@psa-zt.de](mailto:info@psa-zt.de)

CH

### **HSH Handling Systems AG**

Wangenstr. 96 • CH - 3360 Herzogenbuchsee  
Tel (+41) 062/95610-00 • Fax (+41) 062/95610-10  
Internet [www.rna.de](http://www.rna.de) • Email [info@handling-systems.ch](mailto:info@handling-systems.ch)

GB

### **RNA AUTOMATION LTD**

Hayward Industrial Park  
Tameside Drive, Castle Bromwich  
GB - Birmingham, B 35 7 AG  
Tel (+44) 0121/749-2566 • Fax (+44) 0121/749-6217  
Internet [www.rna-uk.com](http://www.rna-uk.com) • Email [rna@rna-uk.com](mailto:rna@rna-uk.com)

E

### **Vibrant S.A.**

Pol. Ind. Famades C/Energía Parc 27  
E - 08940 Cornellà Llobregat (Barcelona)  
Tel (+34) 093/377-7300 • Fax (+34) 093/377-6752  
Internet [www.vibrant-rna.com](http://www.vibrant-rna.com) • Email [info@vibrant-rna.com](mailto:info@vibrant-rna.com)