

Operating instructions

Control units for oscillating drives

ESG 1000

BA

Rhein-Nadel Automation GmbH

Table of contents

Chapt.....	Page
1 Technical data	3
2 Safety notes.....	4
3 Information for starting	4
4 Plan showing the position of the operating elements on the boards	7
5 Dimensional drawing.....	8
6 Connection diagram.....	8



Declaration of conformity
as defined by
Low voltage directive 2014/35/EU
and EMC directive 2014/30/EU

Herewith we declare that the product complies with the following provisions:

Low voltage directive 2014/35/EU
EMC directive 2014/30/EU

applied harmonized standards:

DIN EN 60204 T1
EN 61439-1

remarks:

Rhein-Nadel-Automation

Managing Director
Jack Grevenstein



1 Technical data

1.1 Functional description

The compact design of the control unit can supply all RNA-control units up to a load current of 6 ampere. It is intended for individual installation directly at the oscillating drive and completely pluggable. The correcting range for the potentiometer in the front plate has been adjusted in the factory at a reference drive and allows the adjustment of the output voltage from 40 to 280 volt_{eff}.

The illuminated rocking switch in the front plate separates the control unit with 2 poles from the mains. For frequent switching or operation with a superordinated control unit there is the possibility of wattless disconnection by means a potential-free contact as well as by 16-30VDC voltage signal. The intervention into the device necessary for that is described under point 3.5, **Release of the function by external components**.

The soft start, a time-controlled bringing-up of power to the adjusted value after switching on, is fixed with approx. 0.5 seconds. If necessary this time can be changed in the device.

1.2 EC - Conformity

The control device corresponds to the following regulations:

Low voltage directive 2014/35/EU
EMC directive 2014/30/EU

Applied harmonized standards:

DIN EN 60204 T1
EN 61439-1

The control device corresponds also to the UL/CSA regulations.

1.3 Technical data

Mains connection:	230 Volt AC, 50/60 Hz, +10 -15% or 115 Volt AC, 50/60 Hz, +10 -15% , internally selectable
Output voltage:	40...208 Volt (eff.) adjustable, (230 V mains) 20...105 Volt (eff.) adjustable, (115 V mains)
Load current:	max. 6 Amp.(eff)
Safety fuse:	Fine-wire fuse 5 x 20; 6,3 MT time-lag
Operating modes:	1. symmetric full wave operation (oscillating frequency = double mains frequency) 2. asymmetric half wave operation (oscillating frequency = mains frequency)
Operating mode selection:	Encoding bridge in the load plug
Function release:	selectable by internal jumpers
Release by external contact:	potential-free make contact, load approx. 6 mA
Release by external signal:	Reverse battery protected input, level 16...30 VDC at 24 Volt approx. 8 mA
Soft start:	internally adjustable, standard approx.. 0,5 sec.
Insulation type:	IP 54
Radio interference suppression:	according to EMV - regulations
Dimensions:	104 x 213 x 153 (width x height x depth)

2 Safety notes

The safety notes shall in any case be read and understood. Their observance secures the conservation of valuable material and avoids health impairment.



The symbol of the pointing hand is shown in these operating instructions at points, which must be particularly observed, so that recommendations, regulations, notes and the correct procedure of work can be observed, as well as damage and destruction of the machine and/or other equipment parts is avoided.



Electric danger, eg. at work under voltage



Work at electrical equipment of the machine/equipment may only be carried out by a qualified electrician or by trained personnel under direction and supervision of a qualified electrician according to the electronic regulations!

All safety and danger notes at the machine / equipment must be observed!!

The electrical equipment of a machine / equipment must be examined regularly. Faults, eg. loose connections or damaged cables, must be eliminated immediately!



Before opening the device unplug the power plug!

3 Information for starting.



Before the mains connection is made and the control unit is switched on, the following points must in any case be checked:

- Is the control unit closed properly and with all screws?
- Are the existing plug fixing devices locked into place/screwed down?
- Are all cables and ducts undamaged?
- Is the **INTENDED USE** guaranteed?
- Does the mains voltage indication comply with the local power supply network?
- Does the mains frequency indication at the oscillating drive comply with the local power supply network?
- Is the correct operating mode set at the control unit? (on that read explanation operating mode)

Only if all above mentioned questions can be answered with yes, the control unit can be put into operation.



At initial starts or starts after repair work or exchange of control units/oscillating drives the minimum output should be set at the control unit before switching on the device. When bringing up the output it must be taken care for correct function.

3.1 Explanations on the term OPERATING MODE

RNA - Oscillating drives are mechanical spring vibrators, which, according to weight and/or size, are adjusted to an oscillating frequency near the mains frequency. Two operating modes are possible:

1. Asymmetrical half-wave operation - the oscillating drive operates with mains frequency.
2. Symmetrical full-wave operation - the oscillating drive operates with double mains frequency.

From that the following details result for the oscillating frequency:

Mains frequency	50 Hz	60 Hz
Operating mode 1	Oscillating frequency 50 Hz = 3000 min ⁻¹	Oscillating frequency 60 Hz = 3600 min ⁻¹
Operating mode 2	Oscillating frequency 100 Hz = 6000 min ⁻¹	Oscillating frequency 120 Hz = 7200 min ⁻¹

At a mains with 50 Hz only oscillating drives with 50 Hz or 100 Hz oscillating frequency can be operated, at a mains with 60 Hz, however, only oscillating drives with 60 Hz or 120 Hz oscillating frequency. The control unit can operate in both operating modes. It must, however, be switched into the correct operating mode. The mains frequency is of no importance for the control unit.

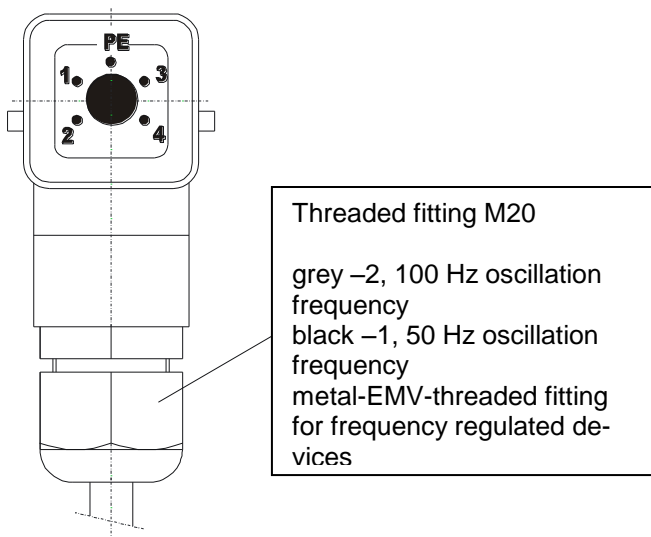

3.2 Switching over to a different mains voltage

The selection of the operating mode takes place by entering a code into the load plug of the oscillating drive. A jumper in the plug from connection 3 to 4 switches the control unit into operating mode 2: 100 or 120 Hz. If this connection is missing, the control unit operates in the operating mode 1: 50 or 60 Hz.

As a standard oscillating transport units are provided with the correct code in the plug. To assist the user, the threaded cable fitting has distinguishing colours on the connector jack for better recognition

BLACK for operating mode 1, 50 Hz or 60 Hz, GREY for operating mode 2, 100 Hz or 120 Hz.

3.3 Setting the minimum and maximum output voltage

The control units have been adjusted in the factory at a reference drive. In special cases or after modifications a readjustment may become necessary. Here it must in any case be observed:



The output voltage can only be measured with an oscillating drive being connected!

The measuring device must be designed for **real effective measurement**. (True-RMS), other measuring devices indicate random values. The load plug must be plugged in, as otherwise the measurement possibly

takes place in the wrong measuring mode.

As the adjustment of the output voltage requires feeding of the mains voltage, the following safety note is very important:



Feed the supply voltage only by means of a **safety transformer** ! Carry out the measurements in the rooms/zones permitted for that. This measurement requires the employment of qualified professionals. After the measurement the control device must be put back into the original condition, as otherwise the release of series is stopped!

Important is the remark that the adjusting devices for the output voltage are not reactionless towards each other. I. e. that at a change of the maximum voltage the minimum voltage is slightly changed as well - and vice versa. That possibly means a repeated adjustment of both trimming potentiometers.

3.4 Switching over to a different mains voltage

The control unit can be operated at 230 V, 50/60 Hz as well as at 115 V, 50/60 Hz, must, however, be switched over to this voltage ,

Changing from 230V to 115V:

Take the plug out of the electrical socket and open the device on the right side. Toggle the switch and close the side of the device. Test run. U_{MAX} may have to be re-adjusted.

(See the layout plan for the adjustable parts, figure 3)

3.5 Releasing the function by external components

The standard adjustment of the control unit provides that the oscillating drive starts, when the mains switch is switched on. Should it be preferred that the control unit work in start-stop operation, then the control unit should be opened — observing all of the precautionary measures listed above — and the jumper S1 re-plugged; see layout plan, figure 3. Remove the dummy plugs on the side of the casing and install a threaded cable fitting M16 with strain-relief; the cable will be fed through here for release. Release is achieved in two possible ways:

Release by a contact

This simple, cost-efficient solution works in a way that the control unit is released by making the contact and the oscillating drive operates. The connection is made at the terminals 33 - 34. Some points should be observed:

- The connection is fed with mains voltage! Cable type and colour, insulation regulations must be observed, the contact must of course be potential-free.
- Starting at 2 m and above, the cable must be shielded; the shielding is situated on one side of the control unit on the protective earth conductor.
- The cable length should not exceed 5 meter.
- The cable may not be installed in immediate neighbourhood to high-energy switching equipments or strong interference fields.

3.6 Changing the soft start time

The soft start, the time-controlled bringing up of the output to the adjusted value is an effective protection for the oscillating drive against magnet impacts. At small oscillating drives, which start with high cycle times, the standard time is not necessary in any case, it does even impede the production flow. At the trimmer SOFT START the run-up time can be adjusted. As the case must be opened for this change as well, the safety notes mentioned above should be observed.

4. Plan showing the position of the operating elements on the boards

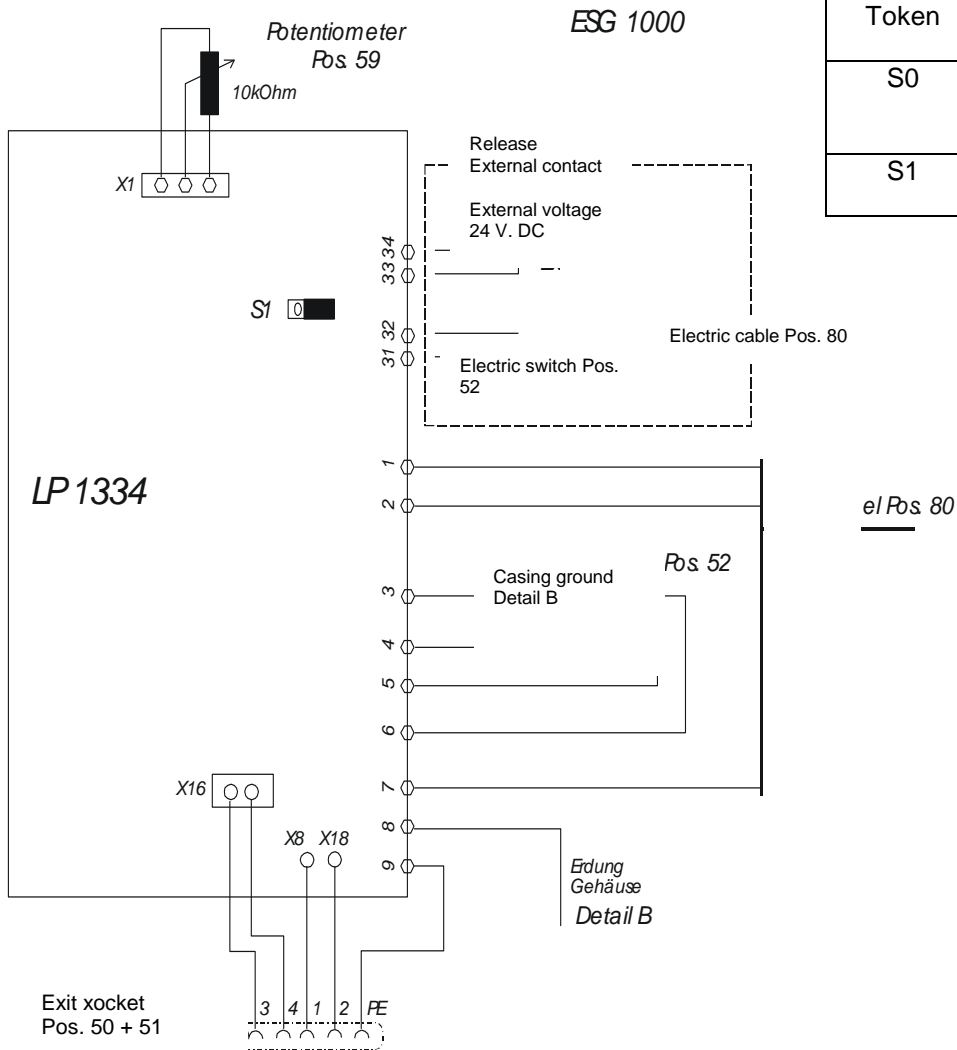

Token	Commentasy
S0	Switch 110 V – 230 V Electric voltage
S1	External release

 When replacing the fuse the preset value of M 6,3 A is to be used in any case. A fuse which is rated too high can lead to breakage of the control unit.

Release by voltage signal

The connection is done on the fasteners 31 (GND) and 32 (+24 VDC). The drive starts, when a signal is fed between 10 and 30 volt direct current in correct polarity. The input is protected against faulty polarity. The use of an optocoupler in the control unit makes the input potential-free and allows the installation with unscreened cables of nearly any length. Here too high-energy interferences should be avoided.

5. Scale Drawing

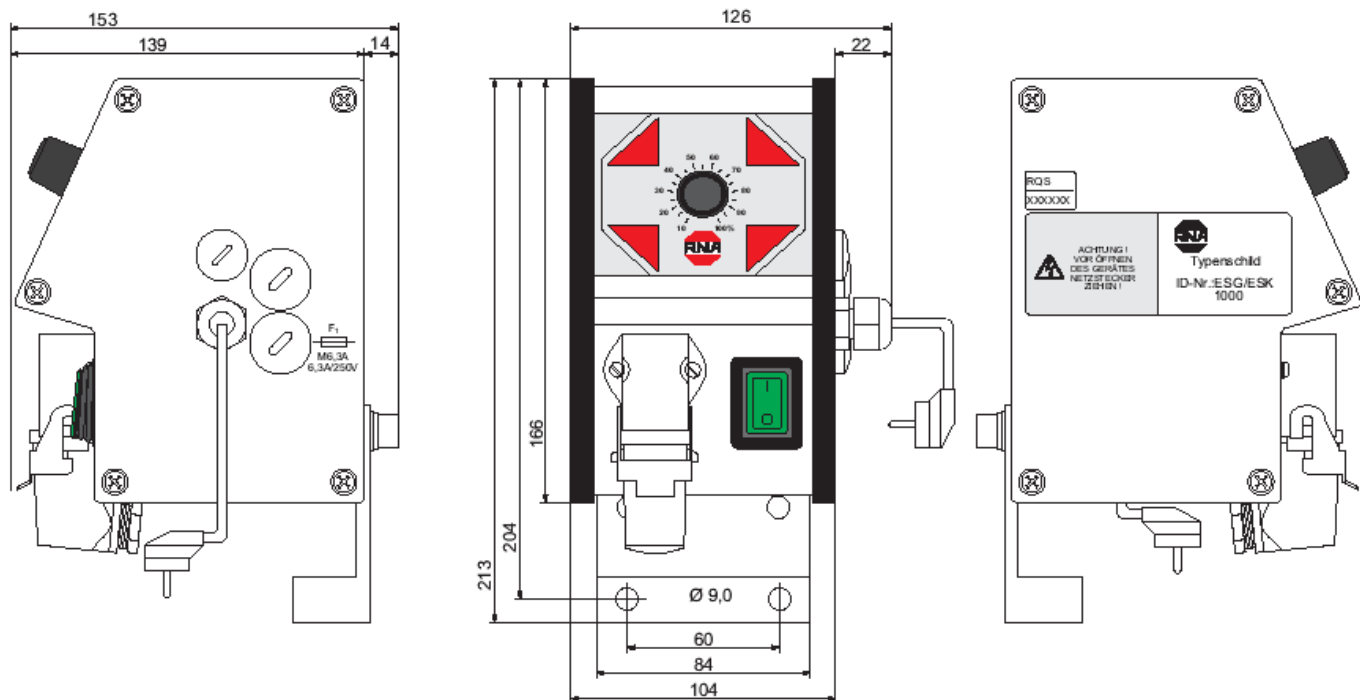

6. Connecting Diagram

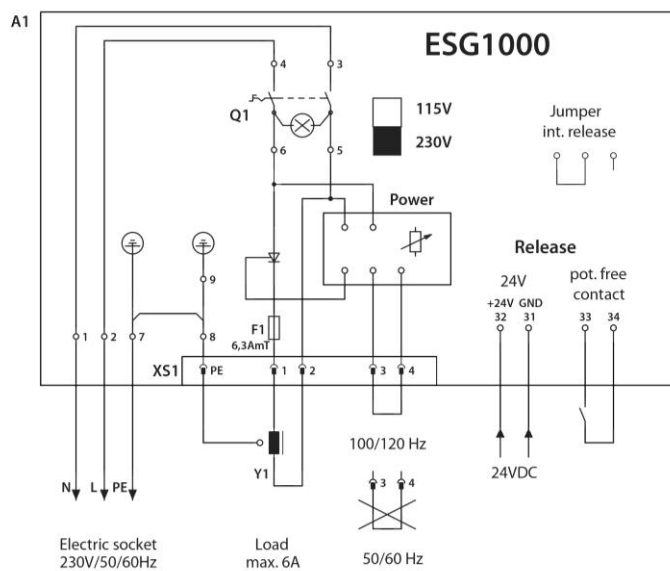

The jumper must be diverted to enable the external release.

ATTENTION! The connectors for the release contacts are under voltage!

The bowl feeder operates when the release signal is passed or when the release contact is closed.

Operation selection:

Connectors XS 1/3 -> 4 connected,
oscillation frequency = double the current frequency

Connectors XS 1/3 -> 4 open, oscillation frequency = current frequency

D**Rhein-Nadel Automation GmbH**

Reichsweg 19/23 • D - 52068 Aachen
Tel (+49) 0241/5109-159 • Fax (+49) 0241/5109-219
Internet: www.rna.de • E-mail: vertrieb@rna.de

Rhein-Nadel Automation GmbH

Zweigbetrieb Lüdenscheid
Nottebohmstraße 57 • D - 58511 Lüdenscheid
Tel (+49) 02351/41744 • Fax (+49) 02351/45582

Rhein-Nadel Automation GmbH

Zweigbetrieb Ergolding
Ahornstraße 122 • D - 84030 Ergolding
Tel (+49) 0871/72812 • Fax (+49) 0871/77131
Email wer.ergolding@rna.de

PSA Zuführtechnik GmbH

Dr. Jakob-Berlinger-Weg 1 • D – 74523 Schwäbisch Hall
Tel +49 (0)791/9460098-0 • Fax +49 (0)791/9460098-29
Email info@psa-zt.de

CH**HSH Handling Systems AG**

Wangenstr. 96 • CH - 3360 Herzogenbuchsee
Tel (+41) 062/95610-00 • Fax (+41) 062/95610-10
Internet: www.rna.de • E-mail: info@handling-systems.ch

GB**RNA AUTOMATION LTD**

Hayward Industrial Park
Tameside Drive, Castle Bromwich
GB - Birmingham, B 35 7 AG
Tel (+44) 0121/749-2566 • Fax (+44) 0121/749-6217
Internet: www.rna-uk.com • E-mail: rna@rna-uk.com

E**Vibrant S.A.**

Pol. Ind. Famades C/Energia Parc 27
E - 08940 Cornellà Llobregat (Barcelona)
Tel (+34) 093/377-7300 • Fax (+34) 093/377-6752
Internet : www.vibrant-rna.com • E-mail: info@vibrant-rna.com