



Assembly Instructions

Hoppers

Type BV

Type BVL

Table of Contents

1.	Technical Data	4
1.1.	Pin assignment	4
2.	Safety Instructions.....	7
2.1.	Applicable Directives and Standards	8
3.	Transport and Assembly	9
3.1.	Transport	9
3.2.	Assembly	9
4.	Putting into Operation	9
5.	Maintenance	9
6.	Stockkeeping of Spare Parts and Customer Service	10
7.	What happens if ...? (Tips for troubleshooting)	10



Declaration of Incorporation

in terms of the Machine Directive 2006/42/EC

We herewith declare that the product is provided for incorporation in a machine or to be assembled with other machines to constitute a machine as defined by the above-mentioned Directive (or parts of it), and that it is not allowed to be put into operation until the machine into which the above is to be incorporated is in conformity with the provisions of the EC Machine Directive.

Applied harmonised standards: DIN EN 60204 T1, DIN ES ISO 12100-2011-03DIN EN 619

Comments:

The product has been manufactured according to the Low Voltage Directive 2014/35/EU.

We assume that our product will be integrated in a stationary machine.

Rhein-Nadel-Automation
-Managing Director

Jack Grevenstein



1. Technical Data

1.1. Pin assignment

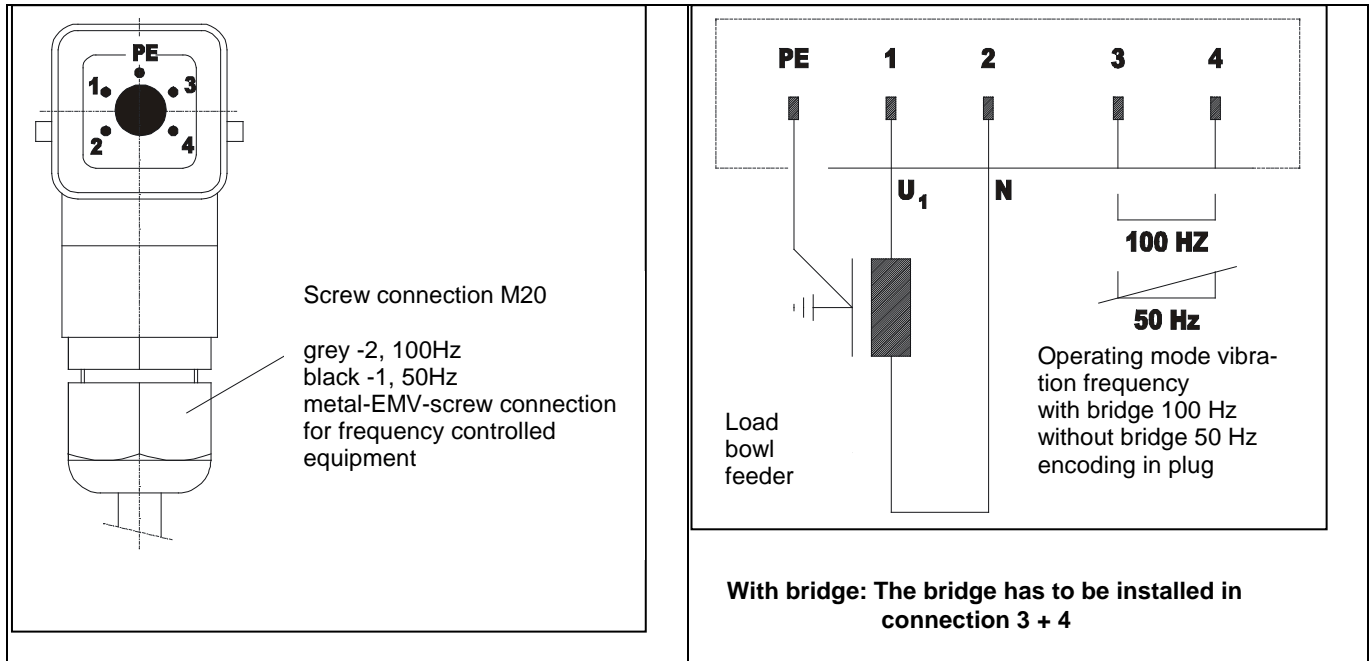

Note

All the linear feeders listed in the table are to be operated only in combination with an RNA control unit at a mains voltage of 230 V / 50 Hz. For special voltages and frequencies, please refer to the separate data sheet.

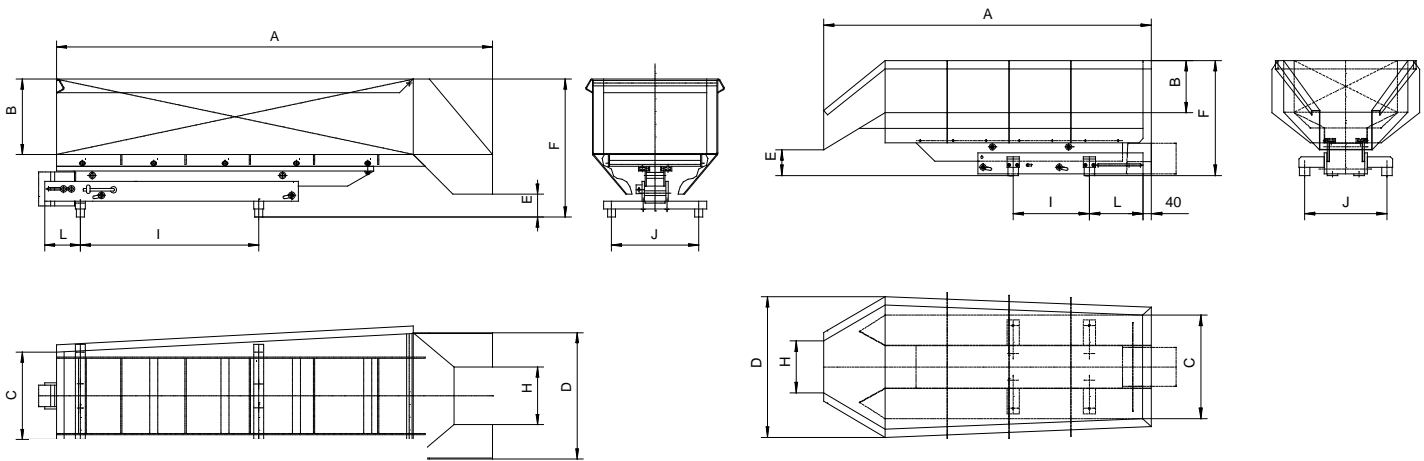

		BV 15	BV 30	BV 60	BV 100	BV 150	BV 200
Filling volume	8 l	15 l	30 l	60 l	100 l	150 l	200 l
Filling weight	30 kg	30 kg	35 kg	100 kg*	150 kg*	200 kg*	200 kg*
Drive	SLL 400-400	SLL 400-400	SLL 400-800	SLL 804-800	SLF 1000	SLF 1000	SLF 1000
Leading dimensions (mm)							
A	700	700	1.100	1.250	1588	1588	1588
B	130	170	190	250	200	250	300
C	210	260	220	280	500	500	500
D	266	316	314	389	680	680	680
E	53	53	58	123	124	124	124
F	283	323	348	473	505	555	605
H	122	143	145	172	250	250	400
I	200	200	450	300	370	370	370
J	170	220	220	230	400	400	400
L	90	90	90	180	260	260	260

* The maximum filling weight depends on the nature of the parts.

Designs

Standard design:	<ul style="list-style-type: none"> - Bulk hopper made of St 37-K and PX-coated - Nominal voltage 200 V / 50 Hz - RAL 6011 paint Reseda green
Special design:	<ul style="list-style-type: none"> - Bulk hopper with polyurethane coating - Bulk hopper made of V2A (1.4301) - Special voltages (110V/ 50-60 Hz; 220V/ 50-60 Hz)
Accessories:	<ul style="list-style-type: none"> - Control units - Level monitoring - Substructures

Subject to engineering changes.

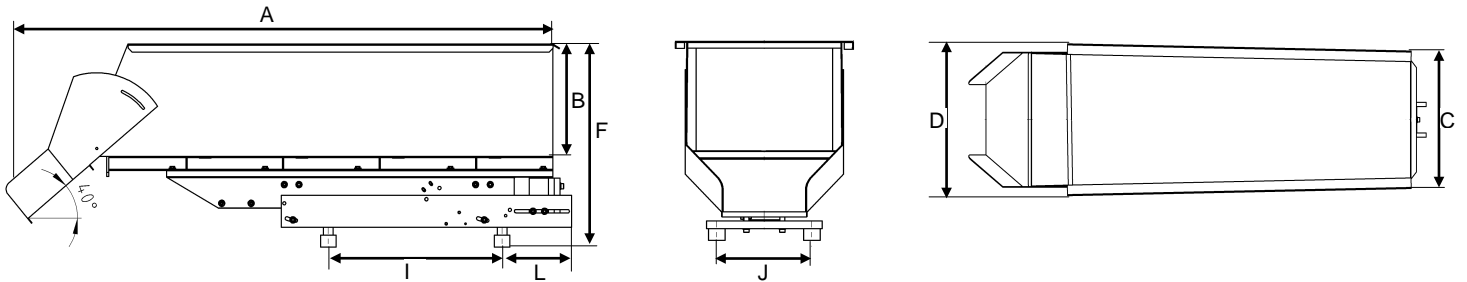
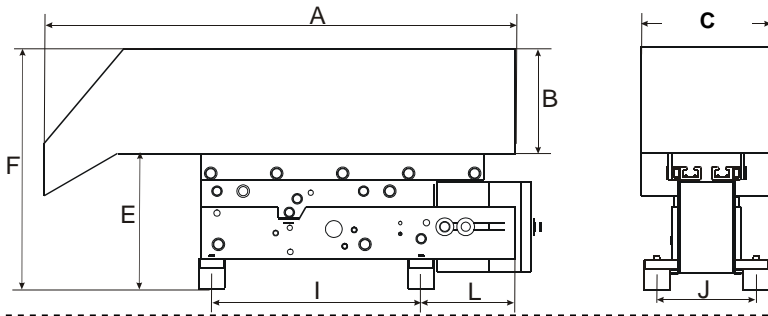
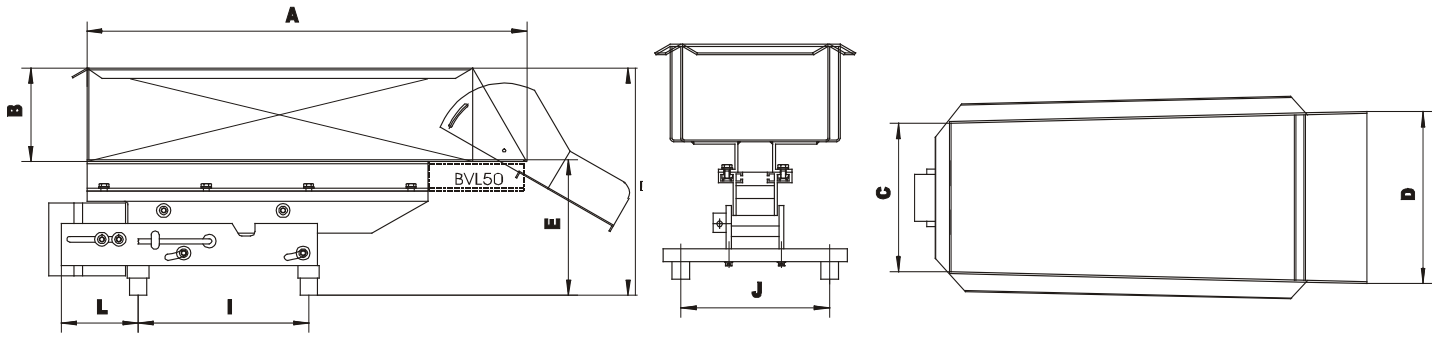

	BVL 3	BVL 5	BVL 15	BVL 25	BVL 50	BVL 100*
Filling volume	3.5 l	7 l	15 l	25 l	50 l	100 l
Filling weight	15 kg	15 kg	20 kg	25 kg	50 kg	50 kg
Drive	SLL 400-400		SLL 400-600	SLL 400-800	SLL 804-800	SLL 804-1000
Leading dimensions (mm)						
A	450	515	700	885	1.015	1.360
B	100	110	150	150	200	285
C	124	170	220	220	280	390
D	124	197	256	256	329	430
E	129	165	163	163	228	
F	229	275	313	313	428	510
I	200	200	300	450	300	450
J	95	170	220	220	230	230
L	90	90	90	90	180	180*

Depending on the number of counterweights used.
Subject to engineering changes.

<i>Designs</i>	
Standard design:	<ul style="list-style-type: none"> - Bulk hopper made of V2A (1.4301) - Nominal voltage 200 V / 50 Hz - Tuning at the works for the indicated filling weight * by BVL 100: including glass bead blast adjustable chute
Special design:	<ul style="list-style-type: none"> - Bulk hopper with polyurethane or MetaLine coating - Special voltages (110V/ 50-60 Hz; 220V/ 50-60Hz)
Accessories:	<ul style="list-style-type: none"> - Control units - Level monitoring - Substructures - Adjustable chute

2. Safety Instructions

We have taken great care in the planning and production of our hoppers to guarantee trouble-free and safe operation. You too can make an important contribution towards job safety by reading these short operating instructions through completely before putting into operation. Always follow the safety instructions!

Make sure that all persons working with or at this machine also read the following safety instructions attentively and observe them!

These operating instructions only apply to the machine types mentioned on the title sheet.



Note

This hand shows that there are instructions to give you helpful hints for operating the linear feeder.



Attention

This warning triangle indicates safety instructions. Non-observance of these warnings can result in serious injuries or death.

Danger of the machine

- Hazards come mainly from the hopper's electrical equipment. If the hopper comes in contact with much moisture, there is the risk of an electric shock!
- Make sure that the protective earthing of the power supply is in perfect condition.

Intended use

The hopper's intended use is the storage and metered feeding of bulk material.

Intended use also means observing the operating instructions and complying with the maintenance regulations.

For technical data about you hopper, please refer to the table "Technical Data". Make sure that the connected loads of the hopper, control system and power supply match.



Note

The hopper may only be operated when it is in perfect condition.

The hopper may not be operated in an explosive or humid area.

The hopper may only be operated with the configuration of drives, control system and feeding bowl as coordinated by the manufacturer.

No additional loads may affect the hopper except for the transported goods for which the special type has been designed.



Attention

It is strictly forbidden to suspend safety devices!

Requirements for the User

- On performing any kind of work (operating, maintenance, repairs, etc.), the indications contained in the operating instructions must be followed.
- The operator must refrain from doing any kind of work that impairs safety at the hopper.
- The operator must make sure that only authorised staff work at the hopper.
- It is the operator's duty to immediately inform his superior of any changes that occur at the hopper.



Attention

The hopper may only be installed, put into operation and maintained by qualified staff. The binding stipulation in Germany for the qualification of specialist electricians and electrotechnically instructed staff applies, as defined in IEC 364 and DIN VDE 0105 Part 1.



Caution: Electromagnetic Field

Persons with pacemakers could be affected by the magnetic field. It is therefore recommended to keep a distance of at least 25 cm.

Noise emission

The noise level at the place of operation depends both on the entire installation and the good to be transported. Should the noise level exceed the permitted limit at the place of operation, noise protection covers can be used, which we offer as accessories.

2.1. Applicable Directives and Standards

The hopper has been built in accordance with the following directives:

- EC Directive "Machinery" 2006/42/EC
- EC Low Voltage Directive 2014/35/EU
- EMC Directive 2014/30/EU

We assume that our product will be integrated in a stationary machine. The User is to follow the regulations of the EMC Directive.

Please refer to the Declaration of Incorporation for the applicable standards.

The hopper is controlled by a low loss electronic control unit type ESG 2000 or type ESG 1000. The hopper's control unit is delivered separately. The control unit has a 5-pole pin-and-socket connector on its front panel which connects it with the hopper.

The pin assignment of the bush is shown in Technical Data.



Note

For full information about the entire range of control boxes, please refer to the operating instructions on "Control Units".

All control units are provided with two essential control elements:

- The **mains switch** enables the linear feeder to be switched on and off.
- A **rotary knob** (or keys) enables the feeding speed of the transport installation to be adjusted.
- Frequency controllers can also be used to balance the hopper. Exact balancing instructions can be found in our operating instructions for Frequency Controllers.

3. Transport and Assembly

3.1. Transport



Note

Make sure that the hopper does not hit any other objects during transport.

3.2. Assembly

The hopper should be mounted onto a stable substructure (available as accessory) at the place of operation. The dimension of this substructure must be such that no vibrations can derive from the linear feeder.

Make sure the hopper cannot touch other devices when in operation.

For further details about the control unit (drilling chart, etc.), please refer to the separately delivered operating instructions of the control unit.

4. Putting into Operation



Attention

One must make sure that the machine frame (stand, base frame, etc.) is connected to the protective conductor (PE). In addition, the customer may have to carry out protective earthing.

Check that

- the hopper stands freely and does not lean against anything solid
- the hopper's connecting cable is plugged in at the control unit.



Attention

Electric connection of the hopper may only be carried out by trained staff (specialist electricians). For any changes on the electrical connection, make sure to follow the operating instructions for "Control Units".

- the available distribution voltage (frequency, tension, power) matches the connection data of the control unit (see rating plate on the control unit).

Plug in the mains cable of the control unit and switch it on with the mains switch.



Note

The optimum feeding capacity of hoppers that are delivered as completely set up systems has already been adjusted at the works. It is marked with a red arrow on the scale of the rotary button. In this case, set the rotary knob to that marking.

The hopper's optimum operative range is at a regulator setting of 80% on the control unit. If there are larger deviations (>+/- 15%), a readjustment should be carried out.

5. Maintenance

The hoppers are basically maintenance-free. They should only be cleaned when strongly soiled or affected by liquids.

- For this, unplug the mains plug.
- Clean the inside of the hopper (after disassembly if necessary), and especially the magnetic gap.
- After assembly and plugging in the mains plug, the hopper is again ready for operation.

6. Stockkeeping of Spare Parts and Customer Service

For an overview of the available spare parts, please refer to the separate spare parts sheet.

In order to guarantee that your order is carried out quickly and correctly, please always indicate the machine type (see type plate), required number of pieces as well as name and number of the spare part.

You can find a list of service addresses on the back cover.

7. What happens if ...? (Tips for troubleshooting)



Attention

Only a specialist electrician may open the control unit or plug. Pull the mains plug before opening!

Defect	Possible cause	Remedy
Hopper does not start when switched on.	Mains switch off. Mains plug of the control unit not plugged in. Connecting cable between hopper and control unit not plugged in. Fuse defect in control unit.	Switch on mains switch. Plug in mains plug. Plug in 5-pole plug on the control unit. Change fuse.
Hopper vibrates only slightly. 	Rotary knob on control unit set to 0%. Transportation security device not removed. Wrong frequency of oscillation. Attention If the hopper is to be operated with a basic linear feeder type SLL 400, make sure the bridge is in the 5-pole plug. Otherwise there is the risk of damage to the magnet and control unit due to overloading.	Set regulator to 80%. Remove transportation security device. Check that the codification in the plug of the linear feeder is correct (see rating plate and "Technical Data" (Chapter 1)).
Hopper starts making loud noises.	Foreign bodies in the magnetic gap.	Switch the hopper off and remove the foreign bodies.



RNA-Group

Headquarters

Production and distribution

Rhein-Nadel Automation GmbH
Reichsweg 19-23
D-52068 Aachen

Tel.: +49 (0) 241-5109-0
Fax: +49 (0) 241-5109-219
E-Mail: vertrieb@RNA.de
www.RNA.de

Following companies of RNA-Group:



Production and distribution

Focus: pharmaceutical industry

PSA Zuführtechnik GmbH
Dr.-Jakob-Berlinger-Weg 1
D-74523 Schwäbisch Hall
Tel.: +49 (0) 791 9460098-0
Fax: +49 (0) 791 9460098-29
E-Mail: info@psa-zt.de
www.psa-zt.de



Production and distribution

RNA Automation Ltd.
Hayward Industrial Park Tameside Drive,
Castle Bromwich, Birmingham, B35 7AG
Großbritannien
Tel.: +44 (0) 121 749-2566
Fax: +44 (0) 121 749-6217
E-Mail: RNA@RNA-uk.com
www.rnaautomation.com



Production and distribution

HSH Handling Systems AG
Wangenstr. 96
CH-3360 Herzogenbuchsee
Schweiz
Tel.: +41 (0) 62 956 10-00
Fax: +41 (0) 62 956 10-10
E-Mail: info@handling-systems.ch
www.handling-systems.ch



Production and distribution

Pol. Ind. Famades c/Energia 23
E-08940 Cornellà de Llobregat (Barcelona)
Spanien
Tel.: +34 (0)93 377-7300
Fax.:+34 (0)93 377-6752
E-Mail: info@vibrant-RNA.com
www.vibrant-RNA.com
www.vibrant.es

*Following production sites
of RNA Group*

Production

Subsidiary Lüdenscheid

Rhein-Nadel Automation GmbH
Nottebohmstraße 57
D-58511 Lüdenscheid
Tel.: +49 (0) 2351 41744
Fax: +49 (0) 2351 45582
E-Mail: werk.luedenscheid@RNA.de

Production

Subsidiary Ergolding

Rhein-Nadel Automation GmbH
Ahornstraße 122
D-84030 Ergolding
Tel.: +49 (0) 871 72812
Fax: +49 (0) 871 77131
E-Mail: werk.ergolding@RNA.de